

RVC900N Series ROTARY VALVE CONTROLLER

User Manual



15 Corporate Drive, Suite E - Wayne - NJ 07470
Tel: (973) 646-5044 E-mail: info@fisnar.com
www.fisnar.com

This page intentionally left blank

1. TABLE OF CONTENTS

1. Table of contents	1
2. Designated use	2
3. For your safety	2
4. Technisa data	3
4.1 Parts & description	4
5. Included parts	5
6. Start operation	5
7. Operation	6
7.1 Display	6
7.2 Status LED's	6
7.3 Operation keys	7
8. Parameter	8
9. Service Menu	9
9.1 Display	9
9.2 Settings	9
10. Electrical connections	10
10.1 Rotary valve	10
10.2 Foot switch	10
10.3 I/O-port	10
10.4 Wiring diagrams	11
11. Maintenance and cleaning	12
12. Disposal	12

2. DESIGNATED USE

The digital rotary valve controller RVC900N is used for precise controlling of rotary valves which work with a DC voltage of 0 – 24V, for example the PDV-1000 valve. The RVC900N controls the air pressure on the material, and also the voltage to the rotary valve for setting the speed of the valve.

With the integrated precision air pressure regulator, the air pressure on the material can be set precisely. There are two different air pressure outputs for the RVC900N. One output is continuous air pressure, the second output is a pulsed air pressure, as long, as the rotary valve dispenses. An integrated digital pressure sensor at the inlet air gives an additional point for the process safety.

3. FOR YOUR SAFETY:

WARNING:

- If the RVC900N is used for other functions as described below, it could come to personal or material damage. Use the RVC900N controller only for the functions, which are explained in this user manual. Fisnar Inc. is not responsible for personal or material damages, which happen because of incorrect usage.
- **DO NOT** modify the RVC900N.
- **DO NOT** attempt to repair or use spare parts without first contacting Fisnar.
- **DO NOT** use anything but recommended Fisnar accessories..

SAFETY PRECAUTIONS:

- The RVC900N works with 100 – 240V AC voltage. By touching the 100 – 240V AC voltage, there exists danger of life!! Because of this, the RVC900N must be disconnected from the AC input cable, before opening the housing. It is only allowed for authorized electrical experts to open the housing.
- DO NOT exceed the maximum allowed power / settings.
- Always wear protective gear.
- Before using the RVC900N please review the safety datasheets of the dispensing material
- No smoking or fire by flammable materials.
- The RVC900N is only allowed for use indoors.
- Due to the electronic nature of this equipment and the potential for a spark or generation of heat, note that this equipment most **NOT** be used with any explosive material or in an explosive type environment.

4. TECHNICAL DATA

Measurements	: 9 1/4" x 8 1/4" x 2 3/4" (235 x 210 x 70mm)
Weight	: 3.6lbs. (1.65kg)
Power Supply	: 100 – 240V AC 50/60Hz
Internal Voltage	: 24V DC
Voltage Rotary Valve	: 0 ... 24V DC (PWM)
Dispense Time	: 0.01 - 999 sec.
Air Inlet	: 0-100psi (0-7bar) Display: digital
Air Outlet	: 0-58 psi (0-4bar) precise pressure regulator - continuous - pulsed
Parameter Display	: 128 x 64 Pixel graphical display
Programs	: 8 programs

4.1 PARTS & DESCRIPTION

[Front Side]

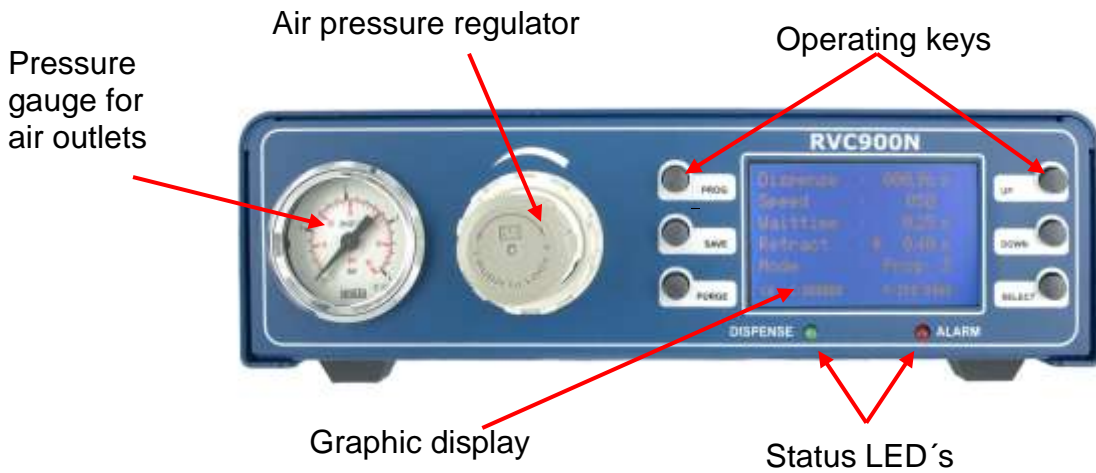

[Back Side]

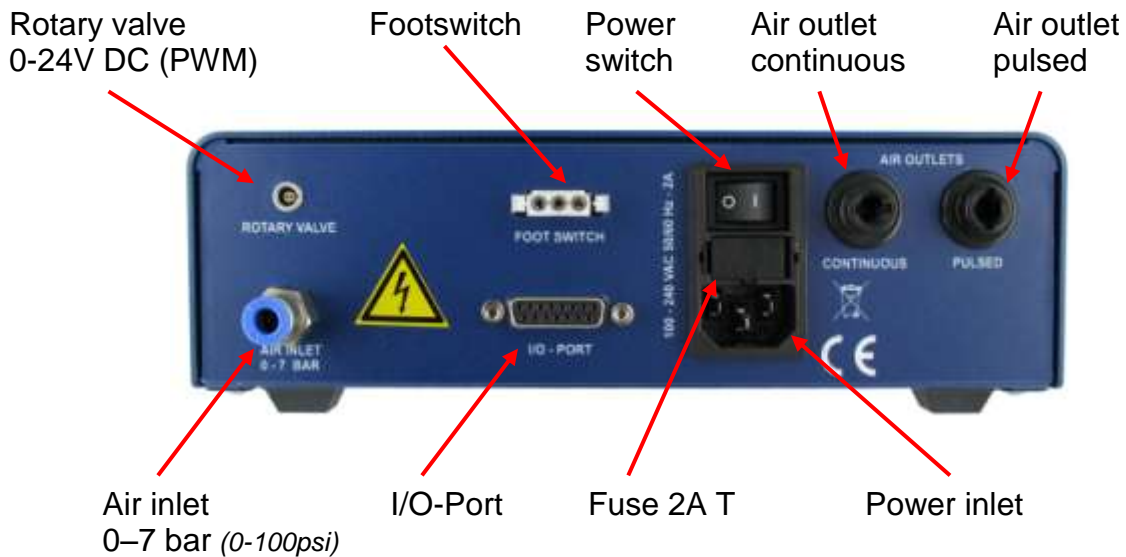

5. INCLUDED PARTS:

- RVC900N Controller
- Power Inlet cable
- Tube for Air Inlet
- User Manual
- Foot Pedal

6. START OPERATION:

- Connect the power inlet cable to the power inlet connector on the backside.
- Connect the air inlet tube from the compressor to the air inlet on the backside of the RVC900N.
- Connect the foot pedal or dispense cable to the footswitch connector on the backside of the RVC900N. Also connect the rotary valve cable to the connector in the rear of the RVC900N controller.
- Depending on your application, use the continuous or pulsed air outlet for the air supply of the material reservoir. Adjust the air outlet pressure with the pressure regulator on the front side of the RVC900N. A typical air pressure is less than 30psi (*2 bar*) for standard applications with a rotary valve. If material comes out of the tip, without dispensing with the rotary valve, reduce the air pressure on the material reservoir.
- Switch the RVC900N on. The display shows the initialization and the installed software version. After 5 sec, the display switches automatically to the standard screen and is ready for operation.
- Check the pressure input (e.g. P-IN: 80psi (*5.6bar*)) in the display to be sure, that the air input pressure is connected.

7. OPERATION:

7.1 Display: (values can be different)

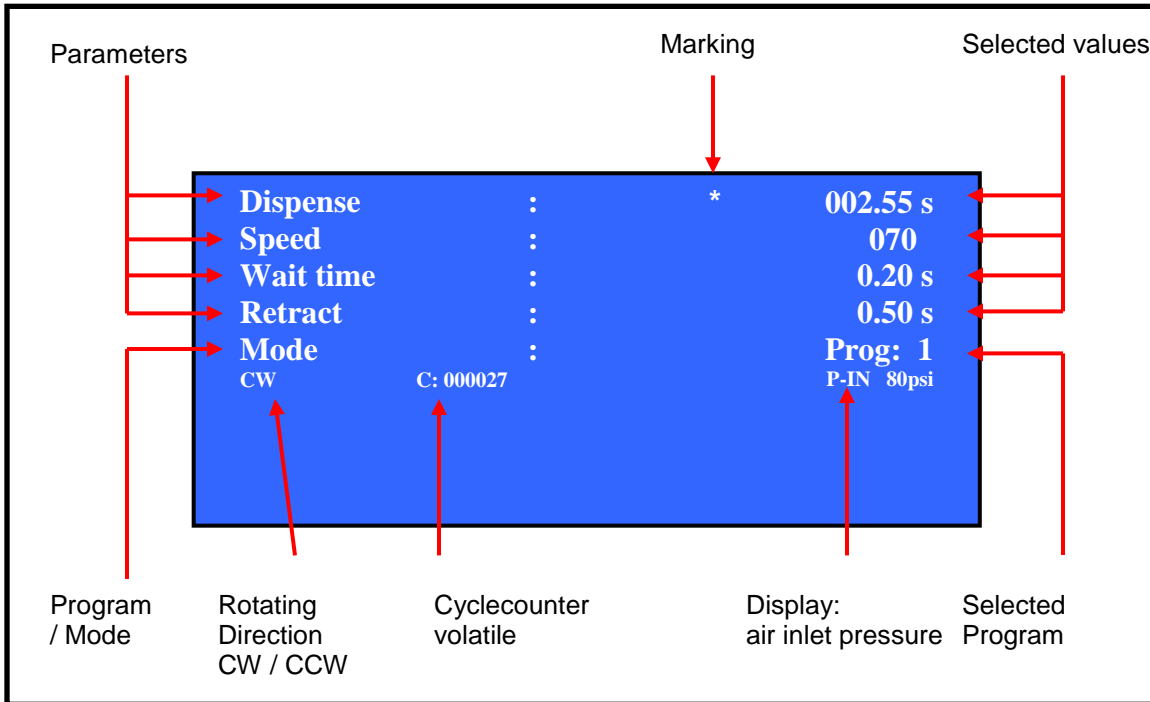

7.2 Status LED's

Below the display are the status-LED's of the RVC900N.

RUN: The RUN LED will turn on when the motor of the rotary valve is running. Independent to the rotation direction.

ALARM: The ALARM LED lights, during the following conditions:

- Pressure alarm is active
- Motor current overload (only active for speed >50)
- External alarm signal on the I/O-Port



7.3 Operating keys:



PROG - switches to the next program



SAVE - saves the actual parameters.

Press the SAVE key for 2 sec. and select the wanted program with the UP / DOWN keys and press SAVE again to store the parameters. If no different program is selected, the parameters get automatically saved in the actual program.



PURGE - starts the dispensing procedure.

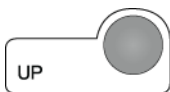

UP - increases the selected value.



DOWN - decreases the selected value



SELECT - Moves the marking to the next display line.

8. PARAMETER:

- **Select mode**

Pressing the PROG key switches to the next program and to manual mode

Manual: In this mode, the dispense time does not get saved and the rotary valve dispenses as long as the dispense signal is activated by one of the following: footswitch / purge key / I/O-start.
After dispensing, the dispense time starts again at 0.00 sec.

PROG 1-7: If one of the programs 1 – 7 is selected, the RVC900N dispenses as long as the value of the dispense time is set for. This dispense cycle is activated by one of the following: footswitch / purge key / I/O-start.
This mode should be selected, if the rotary valve should always dispense for the same time.

- **Set the dispense time:**

The dispense time can be selected with the UP / DOWN keys, and set from 0.01 - 999.99 sec.

- **Set the rotation speed:**

The rotation speed of the rotary valve can be selected in linear steps.
The value from 001 - 100 is related to the rotary valve voltage 0 - 24V.

- **Set the wait time:**

The wait time is the pause time between end of dispensing and starting the retract of the rotary valve. This value is limited to max. 5 sec.

- **Set the retract:**

The retract is the time, which the rotary valve moves in the inverted direction to the dispense direction. With this function, dropping of material out of the dispense tip, after finishing the dispense procedure can be prohibited. This value is limited to max. 5 sec.

- **Cycle counter:**

The cycle counter counts the dispensing procedures after switching ON the RVC900N controller. The memory of the cycle counter is volatile and gets reset to 000000 after switching OFF the unit.

- **Rotation Direction:**

The rotation direction of the rotary valve can be set for clockwise and counter clockwise. The selected direction is shown in the display as follows:

CW: Clockwise - spindle moves clockwise

CCW: Counter clockwise - spindle moves counter clockwise

The rotation direction can be selected in the SERVICE MENU

- **Keylock:**

By pressing SAVE + PRG at the same time, a key lock for the RVC900N can be activated.

An activated key lock is shown in the display (lower right hand corner) with the symbol: 

By pressing SAVE + PRG again, the keylock is deactivated.

9. SERVICE MENU: (press the UP + DOWN keys during initialisation)

9.1 Display:

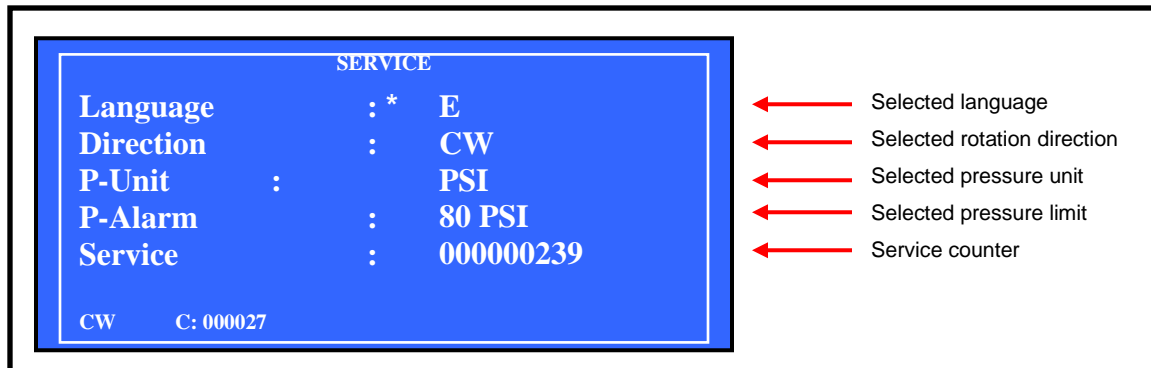

9.2 Settings:

- **Language:**

Pressing UP / DOWN keys switches between English and German language.

- **Direction:**

Pressing UP / DOWN keys switches between CW / CCW rotating direction for the rotary valve:

CW: Clockwise - spindle moves clockwise

CCW: Counter clockwise - spindle moves counter clockwise

- **P-Unit:**

Pressing UP / DOWN keys switches between PSI and BAR as unit for the digital displayed pressure.

- **P-Alarm:**

By pressing the UP / DOWN keys, the value for the low pressure alarm-limit can be selected. If the input pressure is lower than the selected limit, the RVC900N controller switches to ALARM mode and no new dispensing is possible.

- **Service:**

Service counter – not resettable

NOTE: Press the save key to store new settings. The unit will reboot itself.

If you do not want to store new settings, turn off the power and turn on again.

10. ELECTRICAL CONNECTIONS

10.1 Rotary Valve:

type: LEMO connector female 2-pol: EGG.00.302.CLL
 pins: pin 1 (red) 0-24V rotary valve
 Pin 2 0V (GND) rotary valve

mating connector: LEMO connector male 2-pol. FGG.00.302.CLAD35

10.2 Footswitch:

pins: connection between Pin 1 + 3 starts dispensing

10.3 I/O-Port:

type: 15-pol. SubD female 2-doublerow
 pins: see following chart

pin no.	Input / Output	Description:	Comment:
1	--	Reserved	Reserved
2	--	GND	GND
3	--	24V DC	24V DC
4	Output	BUSY	Dispensing procedure active
5	--	GND	GND
6	Input	START	Starts dispensing
7	Input	PRG1	Program select Bit #1
8	Input	PRG3	Program select Bit #3
9	--	Reserved	Reserved
10	--	Reserved	Reserved
11	Output	READY	Ready signal
12	Output	ERROR	Error signal
13	Input	REMOTE	Remote active
14	Input	ERROR-IN	External Error input
15	Input	PRG2	Program select Bit#2

10.4 Wiring Diagrams:

Digital Inputs:

A digital input is active, if the opto coupler is ON. If the opto coupler is connected to GND, the input is activated:

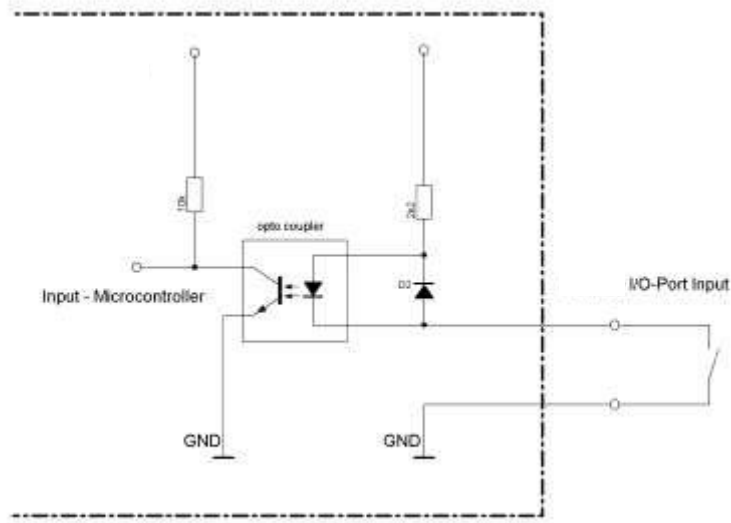

Digital Outputs:

If the digital output is active, the opto coupler is electro conductive.

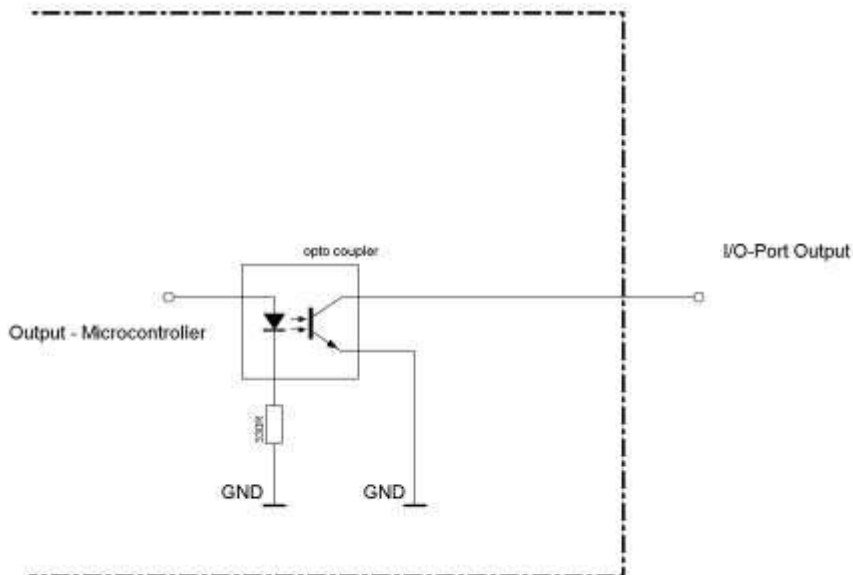

11. Maintenance and cleaning

The RVC900N is maintenance free

Repairs should only be done by the manufacturer.

Clean the RVC900N controller only with a clean, smooth and dry cloth.
Do not use dissolvent material to clean the RVC900N controller. The foil at the front / back plate or the housing paint can be destroyed.

12. Disposal



Dispose the product after the economic life-time according to the legal requirements.